



Rizzetta & Company

# Greyhawk Landing Community Development District

---

**Board of Supervisors' Meeting  
June 25, 2026**

**District Office:  
2700 S. Falkenburg Rd  
Suite 2745  
Riverview, FL 33578**

[www.greyhawkcdd.org](http://www.greyhawkcdd.org)

**GREYHAWK LANDING  
COMMUNITY DEVELOPMENT DISTRICT**

Greyhawk Landing Clubhouse, 12350 Mulberry Avenue, Bradenton, Florida 34212

<b>Board of Supervisors</b>	Jim Hengel Mark Bush Cheri Ady Chad Chester	Chairman Vice Chairman Assistant Secretary Assistant Secretary
<b>District Manager</b>	Matt O’Nolan	Rizzetta & Company, Inc.
<b>District Counsel</b>	Andrew Cohen	Persson, Cohen, Mooney, Fernandez & Jackson, P.A.
<b>District Engineer</b>	Rick Schappacher	Schappacher Engineering, LLC

**All cellular phones must be placed on mute while in the meeting room.**

The Audience Comment portion of the agenda is where individuals may make comments on matters that concern the District. Individuals are limited to a total of three (3) minutes to make comments during this time.

Pursuant to provisions of the Americans with Disabilities Act, any person requiring special accommodations to participate in this meeting/hearing/workshop is asked to advise the District Office at least forty-eight (48) hours before the meeting/hearing/workshop by contacting the District Manager at (239) 936-0913. If you are hearing or speech impaired, please contact the Florida Relay Service by dialing 7-1-1, or 1-800-955-8771 (TTY), or 1-800-955-8770 (Voice), who can aid you in contacting the District Office.

A person who decides to appeal any decision made at the meeting/hearing/workshop with respect to any matter considered at the meeting/hearing/workshop is advised that person will need a record of the proceedings and that accordingly, the person may need to ensure that a verbatim record of the proceedings is made including the testimony and evidence upon which the appeal is to be based.

**GREYHAWK LANDING COMMUNITY DEVELOPMENT DISTRICT**

District Office · Riverview, FL (813-533-2950)

Mailing Address · 3434 Colwell Avenue, Suite 200, Tampa, Florida 33614

[www.greyhawkcdd.org](http://www.greyhawkcdd.org)

**Board of Supervisors Greyhawk  
Landing Community  
Development District**

June 17, 2026

Teams Dail in number: 321-754-9488	Phone conference ID: 709 126 718#
------------------------------------	-----------------------------------

**FINAL AGENDA**

The regular meeting of the Board of Supervisors of the Greyhawk Landing Community Development District will be held on **Thursday, June 25, 2026, at 6:00 p.m.** at the **Greyhawk Landing Clubhouse, located at 12350 Mulberry Avenue, Bradenton, Florida 34212.** The following is the final agenda for this meeting:

- 1. CALL TO ORDER/ROLL CALL/PLEDGE OF ALLEGIANCE**
- 2. AUDIENCE COMMENTS**
- 3. STAFF REPORTS & UPDATES**
  - A. Landscaping Discussion
  - B. Discussion of Aquatic Maintenance Report ..... Tab 1
  - C. Field Manager Report ..... Tab 2
  - D. District Counsel
  - E. District Engineer
    - 1. Consideration of Bank Repair Proposals ..... Tab 3
    - 2. Consideration of Vegetation Removal Proposals ..... Tab 4
    - 4. Discussion of SWFWMD Giddens Parcel ..... Tab 5
  - F. District Manager Report ..... Tab 6
- 4. BUSINESS ADMINISTRATION**
  - A. Consideration of the Operations and Maintenance Expenditures for the Month of April 2026 ..... Tab 7
  - B. Consideration of Minutes of Board of Supervisors Meeting held on April 23 and May 27, 2026, ..... Tab 8
- 5. SUPERVISOR REQUESTS**
- 6. ADJOURNMENT**

We look forward to seeing you at the meeting. In the meantime, if you have any questions, please do not hesitate to contact us at (813) 533-2950.

Respectfully,  
*Matt O'Nolan*  
Matt O'Nolan  
District Manager

# Tab 1



# MONTHLY REPORT

JUNE, 2026



# GREYHAWK LANDING CDD

700 GREYHAWK BLVD  
BRADENTON, FL 34212  
75 PONDS  
3 DITCHES  
31 WETLAND BUFFERS

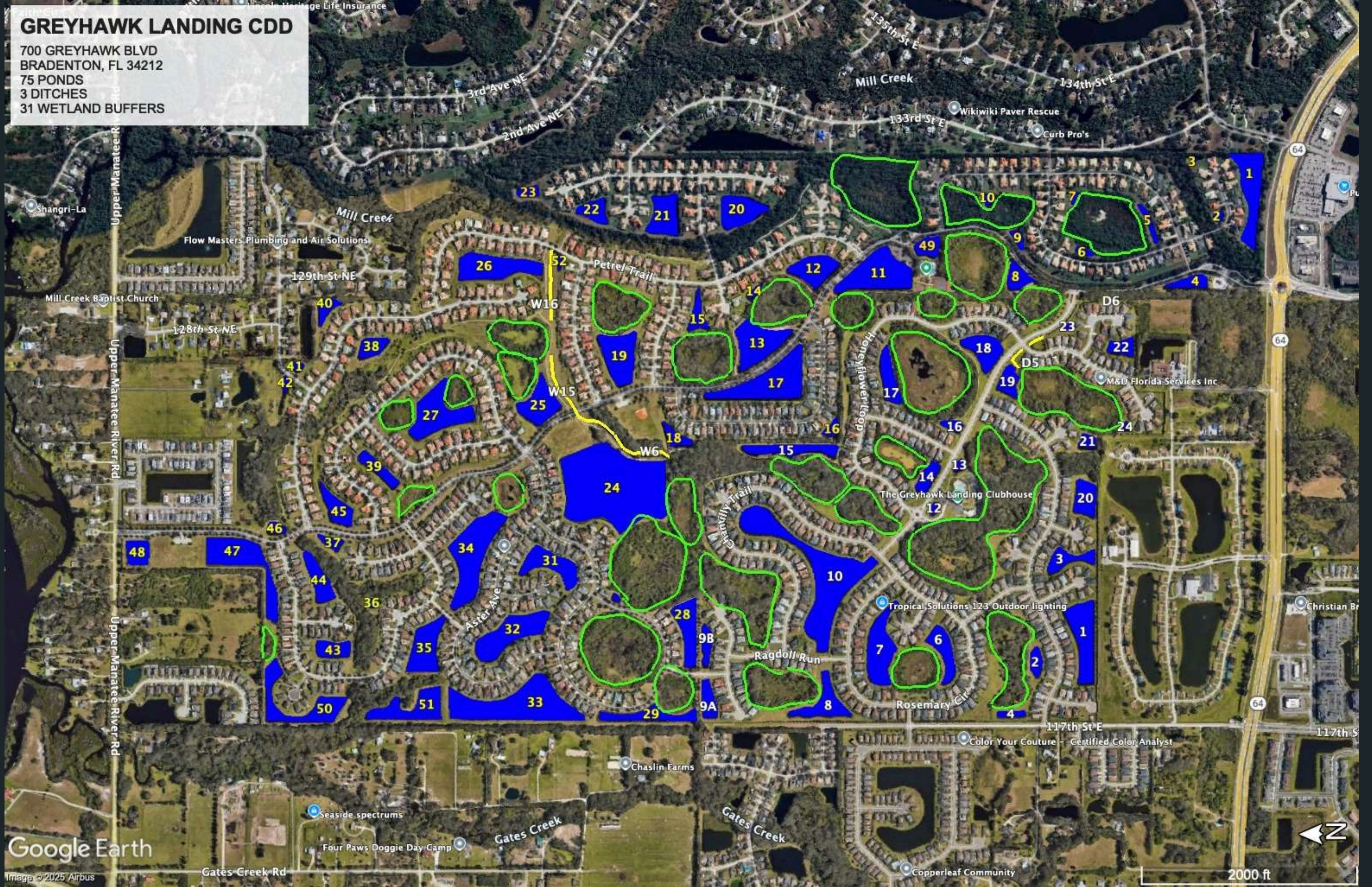

## SUMMARY:

We are still in an extreme drought but hopeful we get some heavy rain coming. As the rain starts couple things to expect are a jump in Algae blooms as runoff water is typically nutrient rich and will spark a bloom. Trash that has been stuck in storm water drains will be washed out into open water and there will be a risk of fish loss on heavy rainfall as ponds may turnover. This is natural but unpleasant.

These are a few things to be aware of but the rain is needed and welcome.



Pond #28 Treated for Hydrilla, Algae and Shoreline Vegetation.

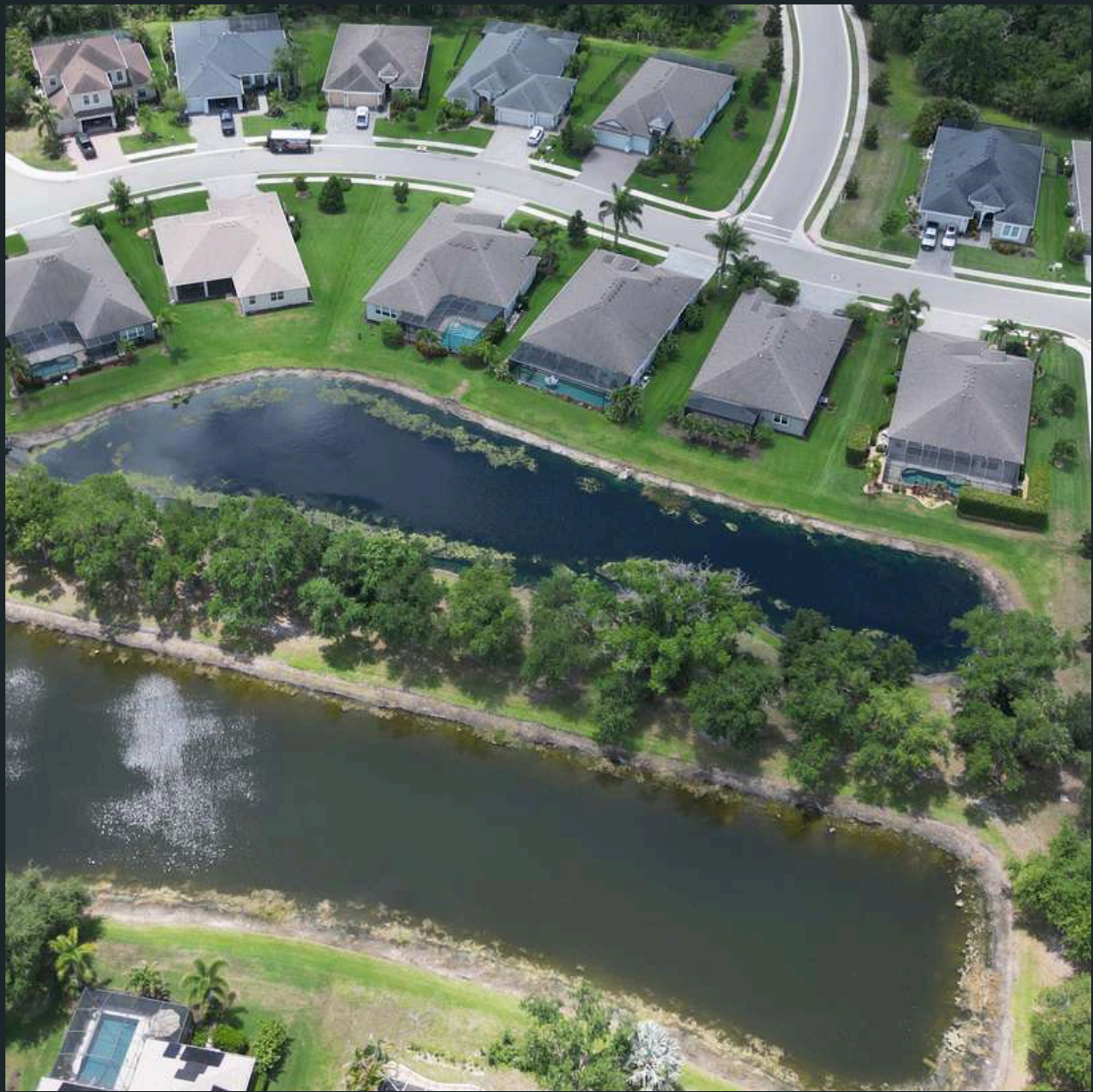

Pond #9B Treated for Hydrilla, Algae and Shoreline Vegetation.

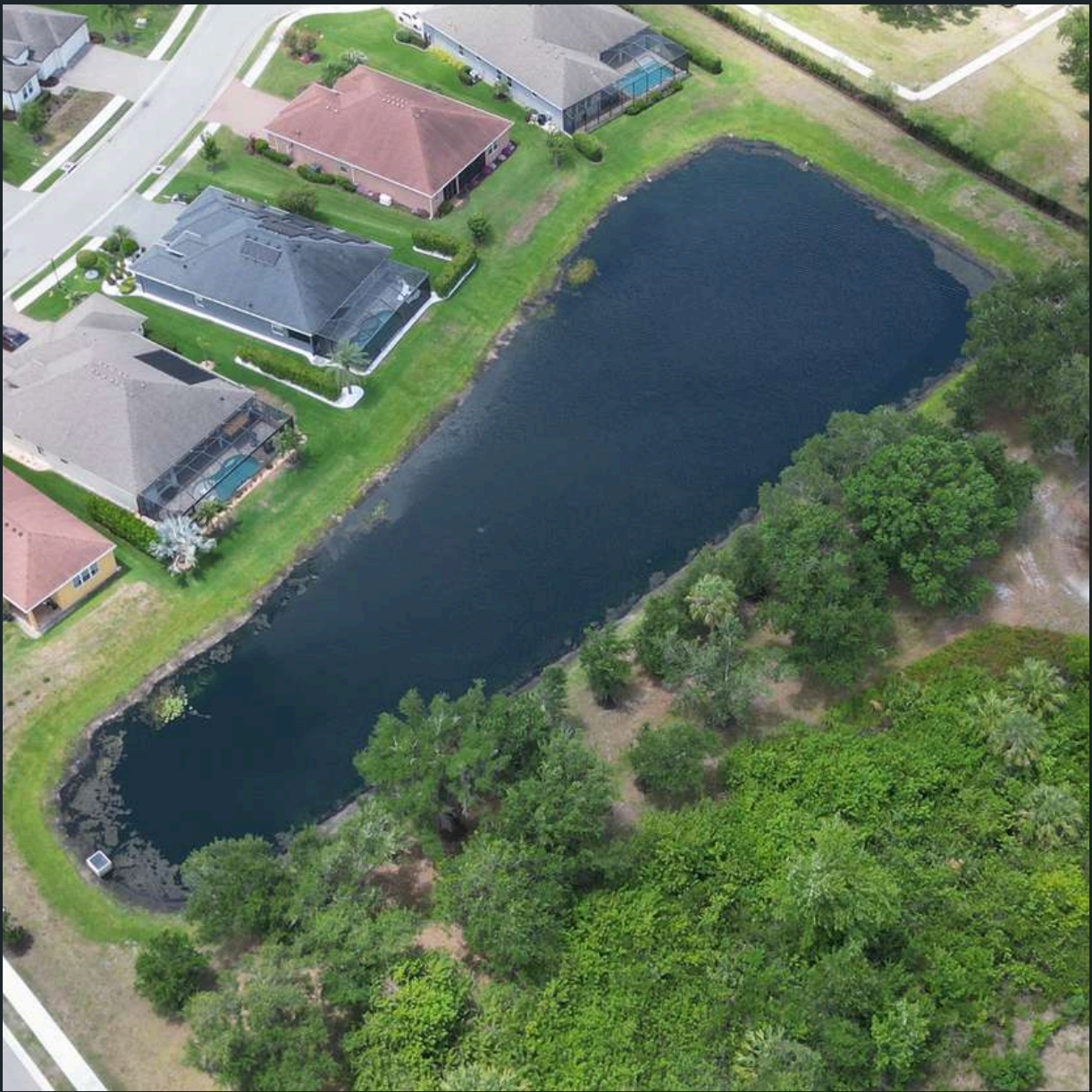

Pond #9A Treated for Algae and Shoreline vegetation.



Pond #10 Treated for Algae and Shoreline Vegetation.



Pond #29 Treated for Algae and Shoreline Vegetation.



Pond #33 Treated for Pond weed and Shoreline Vegetation.



Pond #15 Treated for Duckweed and Shoreline Vegetation.



Pond #32 Treated for Hydrilla, Algae and Shoreline Vegetation.



Pond #45 Treated for Algae and Shoreline Vegetation.



Pond #27 Treated for Algae and Shoreline Vegetation.



Pond #34 Treated for Hydrilla, Algae and Shoreline Vegetation.



Pond #31 Treated for Hydrilla, Algae and Shoreline Vegetation.



Pond #17 Treated for Hydrilla, Algae and Shoreline Vegetation.

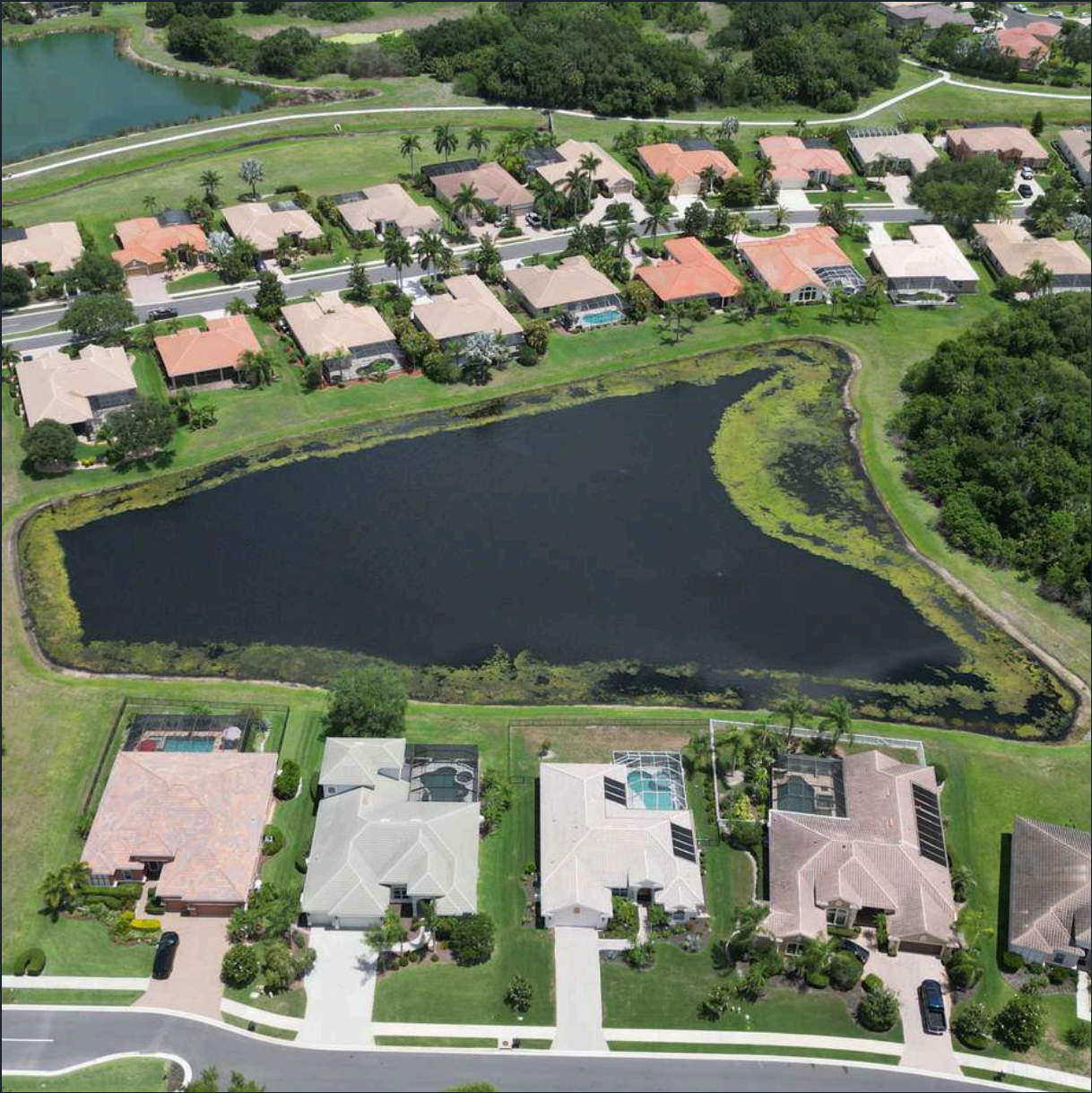

Pond #19 Treated for Hydrilla, Algae and Shoreline Vegetation.



Pond #15 Treated for Algae and Shoreline Vegetation.

# Tab 2



**GREYHAWK LANDING**  
**GREYHAWK LANDING COMMUNITY DEVELOPMENT DISTRICT**  
**FIELD MANAGER MONTHLY REPORT**

Andrew Davis – June 25<sup>th</sup> , 2026

**SITEX AQUATICS:**

- Sitex is actively tending to pond concerns throughout the community.
- Many pond levels are low, due to no rain. This is also the best time to treat submersed vegetation.
- Algae blooms are more prevalent when the pond vendor is treating submersed vegetation.
- A few areas in the conservation zones need to have pepper trees tended to

**SSLM :**

Meetings held on 06/03, and 06/10

- Crews are doing very well, maintaining the grounds of the property. No major issues to report on.

**CDD Facilities Update:**

**Operations/Maintenance Accomplishments for the month (May 27<sup>th</sup> - June 25<sup>th</sup>)**

- The Upper Manatee Entrance is now documenting emergency clicker use (since Monday June 8<sup>th</sup>). Anyone using remotes programmed to the emergency frequency are being documented and sent to code enforcement to receive warning letters.
- Power washing vendor has completed all areas of pressure washing as of Monday, June 8<sup>th</sup>.
- A few of the spring flower installs along GH Blvd. are in great decline. (need to determine cause of decline and consider replacing)

**• Maintenance and Operations**

**Active / Pending projects: Recreation Center**

- Pool slide was replaced on Tuesday, June 16<sup>th</sup> , 2026

**Active / Pending projects: Mulberry Clubhouse**

- Mulberry Pool resurface project – **January 2027**

**Active / Pending projects: Guard House**

- Repairs to the damaged awning at guard house - **pending**

# Tab 3

# Exhibit "A"

## GreyHawk Bank Repairs

Bid Tabulation Form 6.12.26

				Crosscreek Environmental	ANJ Excavation		
Bid Item	Description	Quantity	Unit	Total	Total	Total	Total
1	Area 1 - Remove outflow drain, extend resident installed drain down slope and install pop up at toe of slope at Pond 1	1	LS	900.00	900.00		
2	Area 2 - Remove outflow drain, extend resident installed drain down slope and install pop up at toe of slope at Pond 1	1	LS	900.00	900.00		
3	Area 3 - Add backfill, compact and sod the eroded area behind Lot 13 at Pond 3	1	LS	850.00	1,075.00		
4	Area 4 - Add backfill, compact and sod the eroded area behind Lot 12/13 at Pond 3	1	LS	1,250.00	1,075.00		
5	Area 5 - Install 18" yard drain at top of slope, install pipe down slope into pond and add rip rap at toe of slope at Pond 9	1	LS	1,850.00	2,950.00		
6	Area 6 - Remove existing pop up, connect to existing pipe, install pipe down slope into pond and add rip rap at toe of slope at Pond 15	1	LS	1,700.00	1,875.00		
7	Area 7 - Weld damaged skimmer at Pond 23	1	LS	800.00	850.00		
8	Area 8 - Connect to existing resident installed pipe, install pipe down slope into pond and add rip rap at toe of slope at Pond 23	1	LS	1,350.00	1,600.00		
9	Area 9 - Add crushed concrete under MES, backfill along edges, install filter fabric and 4"-6" rip rap on top and sides at Pond 52	1	LS	1,700.00	1,800.00		
10	Area 10 - Add backfill, compact, add filter fabric and rip rap at toe of slope at Pond 52	1	LS	1,900.00	1,600.00		
11	Area 11 - Add backfill, compact, add filter fabric and rip rap at toe of slope at Pond 16	1	LS	2,350.00	2,400.00		
12	Area 12 - Pour concrete collar around 18" RCP at Pond 29	1	LS	2,200.00	1,800.00		
13	Area 9 - Add crushed concrete under MES, backfill along edges, install filter fabric and 4"-6" rip rap on top and sides at Pond 33	1	LS	1,850.00	1,800.00		
14	Area 14 - Add backfill, compact, add filter fabric and rip rap at toe of slope at Pond 38	1	LS	1,700.00	2,775.00		
15	Area 15 - Add epoxy coated rebar in weir opening, embed rebar into concrete at Pond 2 (Greyhawk West)	1	LS	900.00	750.00		
16	Area 16 - Epoxy patch pick holes at Control Structure at Pond 8	1	LS	300.00	300.00		
17	Miscellaneous cleanup and work	1	LS	1,500.00	250.00		
<b>Total</b>				<b>24,000.00</b>	<b>24,700.00</b>	<b>0.00</b>	<b>0.00</b>

# Tab 4

# Exhibit "A"

## GreyHawk Vegetation Removals

Bid Tabulation Form 6.12.26

				Site X Aquatics	SSLM	Crosscreek Environmental	
Bid Item	Description	Quantity	Unit	Total	Total	Total	Total
1	Area 1 - Clear path and 10' around Outfall Control Structure at Pond 30	1	LS	300.00	420.00	600.00	
2	Area 2 - Clear path and 10' around Outfall Control Structure at Pond 28	1	LS	300.00	420.00	600.00	
3	Area 3 - Clear path and 10' around MES at Pond 33	1	LS	300.00	420.00	600.00	
4	Area 4 - Clear 20' of vegetation in channel on east side of Box Culvert on Lavender Loop	1	LS	450.00	495.00	750.00	
5	Area 5 - Clear path and 10' around MES at Pond 43	1	LS	200.00	420.00	600.00	
6	Area 6 - Clear path and 10' around MES at Pond 36	1	LS	300.00	420.00	600.00	
7	Area 7 - Clear path and 10' around MES at Pond 44	1	LS	300.00	420.00	600.00	
8	Area 8 - Clear path and 10' around MES at Pond 38	1	LS	300.00	420.00	600.00	
9	Area 9 - Clear path and 10' around Outfall Control Structure at Pond 27 (south)	1	LS	100.00	420.00	600.00	
10	Area 10 - Clear path and 10' around Outfall Control Structure at Pond 27 (north)	1	LS	300.00	495.00	600.00	
11	Area 11 - Clear path and 10' around MES at Pond 37	1	LS	250.00	420.00	600.00	
12	Area 12 - Clear path and 10' around MES at Pond 35	1	LS	300.00	420.00	600.00	
13	Area 13 - Clear path and 10' around Outfall Control Structure at Pond 2 (Greyhawk West)	1	LS	100.00	420.00	600.00	
14	Area 14 - Clear path and 10' around Outfall Control Structure from Pond 1 (Greyhawk West)	1	LS	100.00	420.00	600.00	
15	Area 15 - Clear path and 10' around Outfall Control Structure at Pond 6 (Greyhawk West)	1	LS	300.00	495.00	600.00	
16	Area 16 - Clear path and 10' around Outfall Control Structure at Pond 10 (Greyhawk West)	1	LS	300.00	420.00	600.00	
17	Area 17 - Clear path and 10' around Outfall Control Structure at Pond 14 (Greyhawk West)	1	LS	100.00	330.00	600.00	
18	Area 18 - Clear path and 10' around Outfall Control Structure at Pond 18 (Greyhawk West)	1	LS	100.00	330.00	600.00	
19	Area 19 - Clear path and 10' around Outfall Control Structure at Pond 17 (Greyhawk West)	1	LS	50.00	250.00	600.00	
20	Area 20 - Clear path and 10' around Outfall Control Structure at Pond 21 (Greyhawk West)	1	LS	200.00	420.00	600.00	
21	Area 21 - Clear vegetation in front of headwall on west side of Goldenrod Ave.	1	LS	50.00	250.00	200.00	
22	Area 22 - Clear path and 10' around Outfall Control Structure at Pond 20 (Greyhawk West)	1	LS	100.00	420.00	600.00	
23	Area 23 - Clear path and 10' around MES at Pond 1	1	LS	250.00	420.00	600.00	
24	Area 24 - Locate and clear path and 10' around Outfall Control Structure at Pond 5	1	LS	350.00	660.00	750.00	
25	Area 25 - Locate and clear path and 10' around Outfall Control Structure at Pond 6	1	LS	350.00	495.00	750.00	
26	Area 26 - Locate and clear path and 10' around Outfall Control Structure at Pond 8	1	LS	350.00	495.00	750.00	
27	Area 27 - Locate and clear path and 10' around Outfall Control Structure at Pond 7	1	LS	350.00	660.00	750.00	
28	Area 28 - Locate and clear path and 10' around Outfall Control Structure at Wetland 25 (north)	1	LS	350.00	495.00	750.00	
29	Area 29 - Locate and clear path and 10' around Outfall Control Structure at Pond 10	1	LS	350.00	660.00	750.00	
30	Area 30 - Locate and clear path and 10' around Outfall Control Structure at Wetland 24	1	LS	350.00	495.00	750.00	
31	Area 31 - Locate and clear path and 10' around Outfall Control Structure from Pond 11	1	LS	350.00	420.00	200.00	
32	Area 32 - Clear cut palm branches from top of Outfall Control Structure from Pond 14	1	LS	50.00	250.00	750.00	
33	Area 33 - Locate and clear path and 10' around Outfall Control Structure at Pond 23	1	LS	300.00	420.00	600.00	
34	Area 34 - Clear path and 10' around MES at Pond 22	1	LS	300.00	420.00	600.00	
35	Area 35 - Clear path and 10' around MES at Pond 21	1	LS	300.00	420.00	600.00	
36	Area 36 - Clear path and 10' around MES at Pond 20	1	LS	200.00	420.00	600.00	

# Exhibit "A"

## GreyHawk Vegetation Removals

Bid Tabulation Form 6.12.26

				Site X Aquatics	SSLM	Crosscreek Environmental	
<b>Bid</b>							
37	Area 37 - Clear path and 10' around Outfall Control Structure at Pond 19	1	LS	200.00	495.00	600.00	
38	Area 38 - Locate and clear path and 10' around Outfall Control Structure at Wetland 25 (west)	1	LS	300.00	495.00	750.00	
39	Area 39 - Locate and clear path and 10' around Outfall Control Structure at Pond 9	1	LS	300.00	420.00	750.00	
40	Miscellaneous cleanup and work	1	LS	0.00	5,300.00	1,200.00	
<b>Total</b>				<b>9,800.00</b>	<b>22,385.00</b>	<b>25,450.00</b>	

# Tab 5

PERMITTED DRAWINGS SOUTHWEST FLORIDA WATER MANAGEMENT DISTRICT (SWFWMD)  
 For construction permits, the Permittee shall notify the District  
 in writing when construction begins.

Thu, 29 Aug 2024 9:20am V:\acad\Cox Chevrolet SR 64 (44229)\Mass Grading\ENG\COX - MG - DG.dwg



**NOTES:**

A - 1" SURFACE COURSE OF TYPE S-III (OR ALTERNATIVE SP-2.5) ASPHALT WITH A NOMINAL MAXIMUM AGGREGATE SIZE OF 9.5mm (3/8") AND SHALL HAVE A FINAL COMPACTED THICKNESS OF 1.0" MINIMUM. COMPLY WITH THE GEOTECHNICAL RECOMMENDATIONS IF A GREATER THICKNESS IS SPECIFIED.

B - 1.5" OF S-I ASPHALT PER FOOT STANDARD SPECIFICATIONS FOR ROAD AND BRIDGE CONSTRUCTION, 2000 EDITION.

C - 8" BASE COURSE WITH MINIMUM LBR 100 AND COMPACTED TO 98% OF THE MODIFIED PROCTOR DRY DENSITY (AASHTO T-100) VALUE. THE BASE COURSE SHALL CONSIST OF APPROVED CRUSHED CONCRETE, BANK RUN SHELL, OR LIMEROCK MATERIAL.

D - 12" STABILIZED SUBGRADE WITH MINIMUM LBR 40 AS SPECIFIED BY FOOT REQUIREMENTS FOR TYPE B STABILIZED SUBGRADE. THE SUBGRADE SHALL BE COMPACTED TO 98% OF THE MODIFIED PROCTOR DRY DENSITY (AASHTO T-100) VALUE.

**HEAVY DUTY ASPHALT PAVEMENT DETAIL**  
 N.T.S.

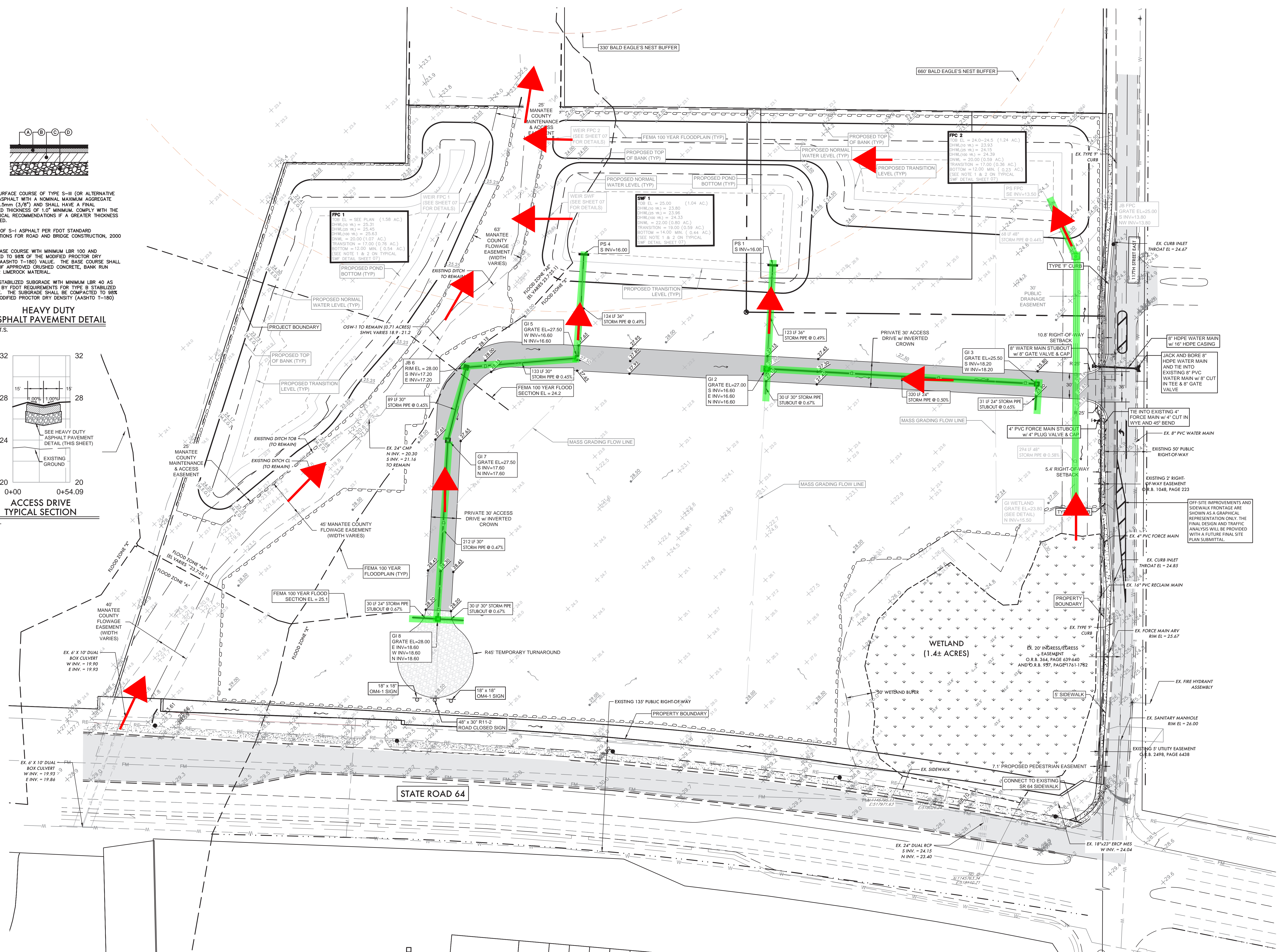
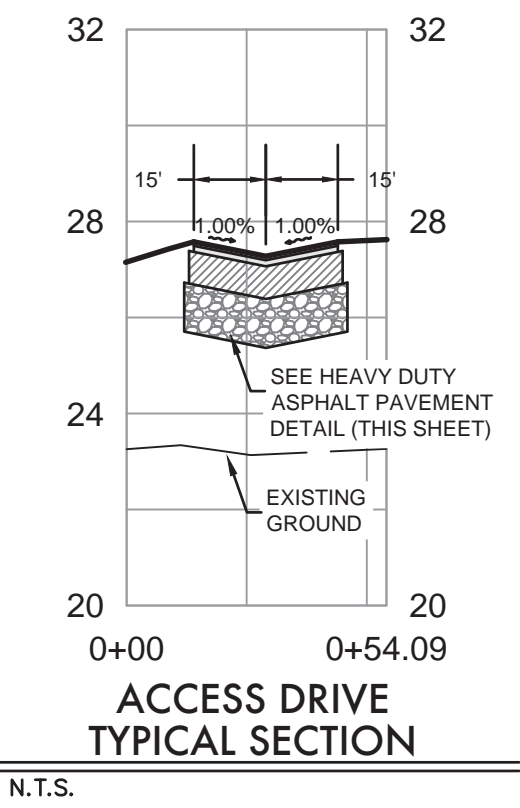

ADAM J. LYON  
 PROFESSIONAL ENGINEER #8648

**ZNS ENGINEERING**  
 Land Planning  
 Engineering Surveying  
 Landscape Architecture

1023 MANATEE AVENUE WEST 7TH FLOOR BLDG 1000  
 TAMPA, FL 33602  
 TEL: 813.241.7431  
 FAX: 813.241.7432  
 WWW.ZNSENGINEERING.COM

REVISIONS

1	
2	
3	
4	
5	
6	
7	

PHASE II ENGINEERING PLAN  
 FOR  
**GIDDENS PARCEL**  
 LOCATED IN  
 SECTION 27, TOWNSHIP 34 SOUTH, RANGE 19 EAST  
 MANATEE COUNTY, FLORIDA

DESIGNED: AL  
 DRAWN: EC  
 DATE: 07/2023  
 JOB NO: 44229  
 SCALE: 1" = 50'  
 SHEET: 00A

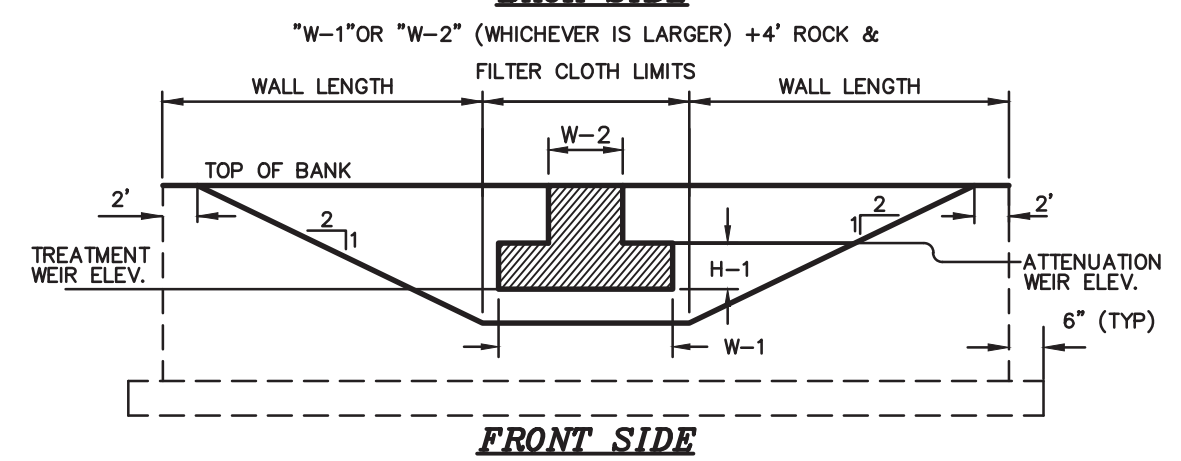
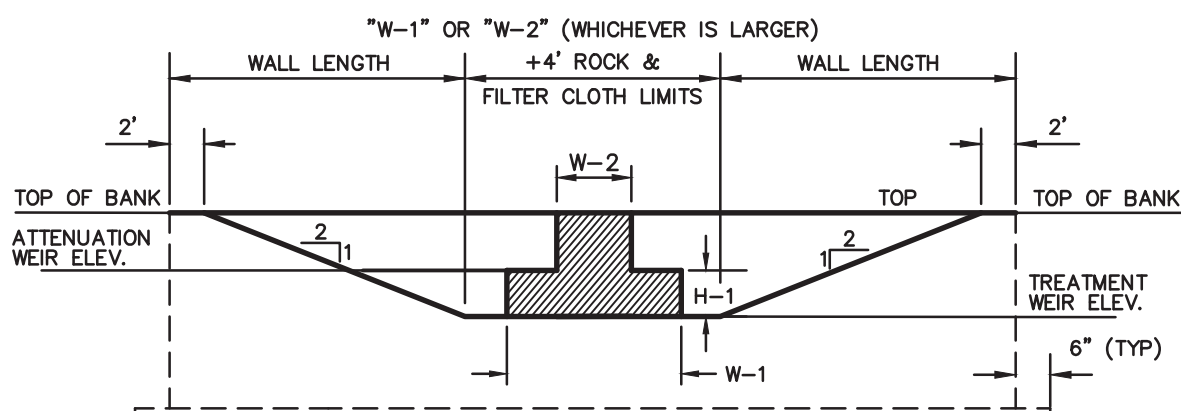
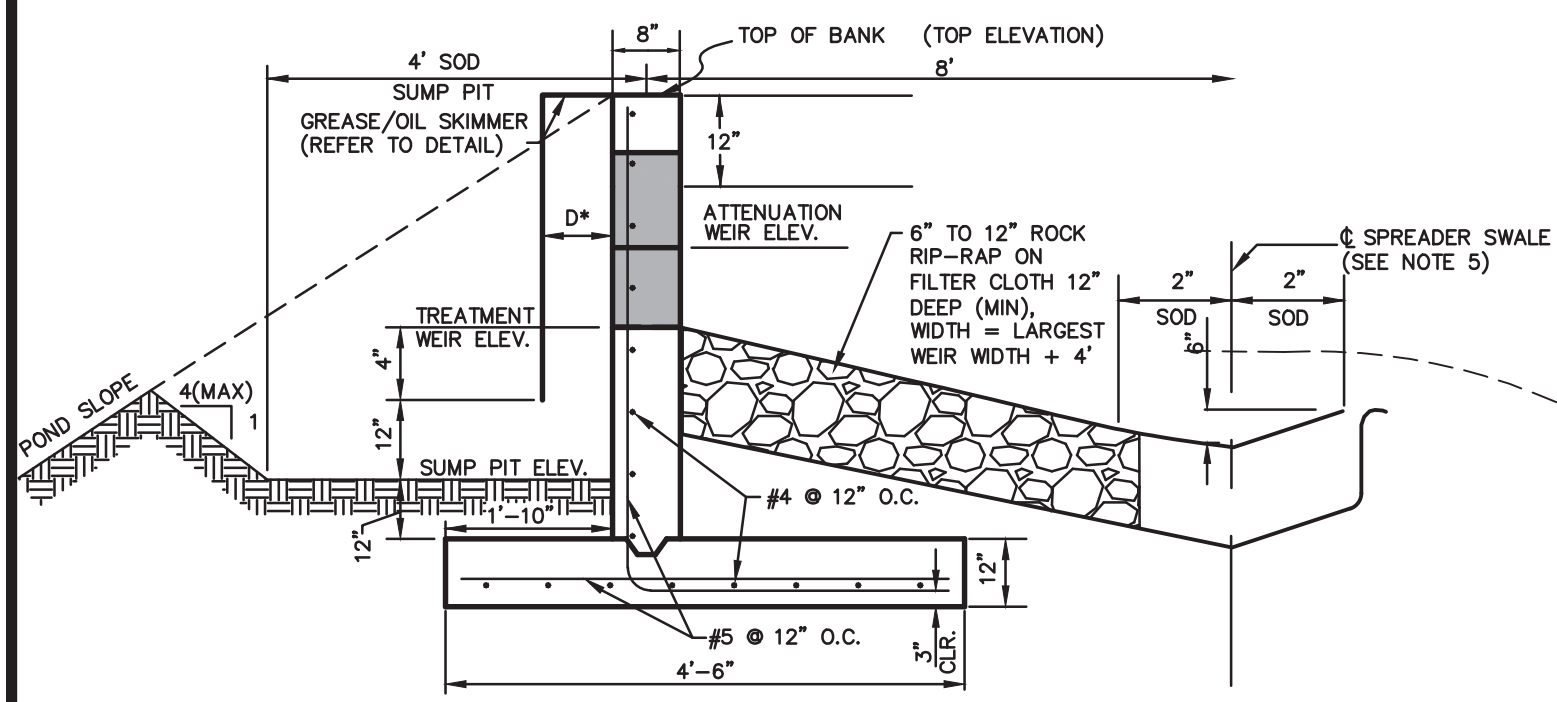

- NOTES:**
- CONTRACTOR TO SUBMIT SHOP DRAWINGS FOR APPROVAL PRIOR TO CONSTRUCTION. SHOULD ANY VARIANCE OF THIS DETAIL BE NECESSARY.
  - BENCH MARKS WITH THE ELEVATION CLEARLY AND PERMANENTLY MARKED ARE TO BE PLACED ON THE TOP OF ALL OUTFALL CONTROL STRUCTURES.
  - GREASE/OIL SKIMMER TO BE ATTACHED TO SWF SIDE OF STRUCTURE (PER DETAIL).
  - CONCRETE 3,500 PSI @ 28 DAYS
  - CONTRACTOR IS TO LOCATE, VIA SURVEY, THE LOCATION OF THE OUTFALL THAT WILL MATCH THE "TREATMENT OR ATTENUATION" WEIR ELEVATION (WHICHEVER IS LOWER) AND BUILD OUTFALL SWALE TO THAT LOCATION.

**WEIR DETAIL**

**WEIR DATA CHART**

WEIR NUMBER	TOP ELEVATION	TREATMENT WEIR ELEVATION	"W-1" (inches)	ATTENUATION WEIR ELEVATION	"W-2" (inches)
FPC #1	25.25	N/A	N/A	20.00	30
FPC #2	24.00	N/A	N/A	20.00	60
SWF #1	25.00	22.00	14	22.55	60

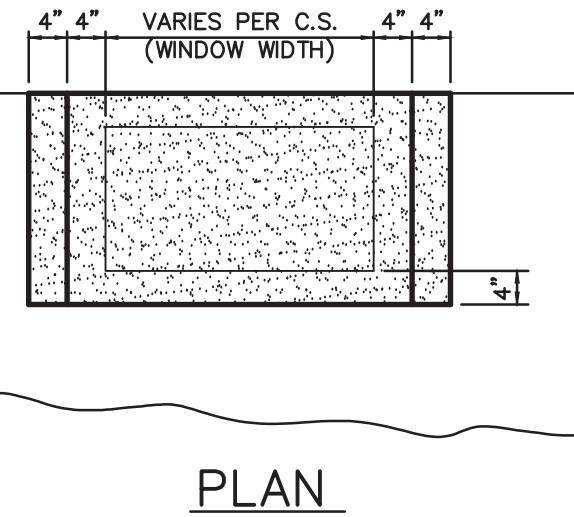
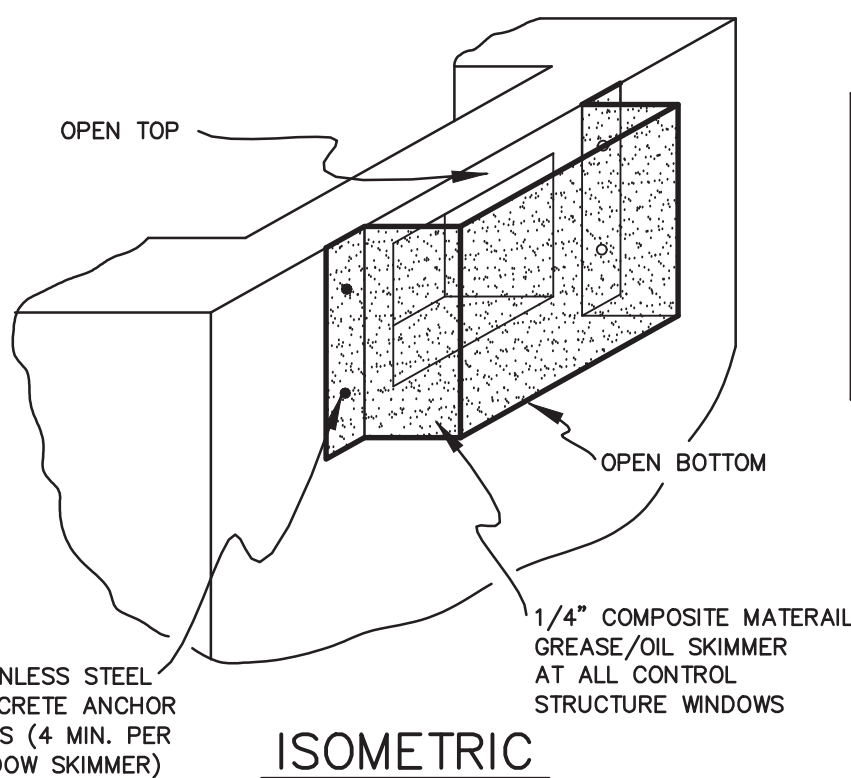

**PLAN**

**GREASE/OIL SKIMMER DETAIL**

N.T.S. (TO BE USED ON ALL CONTROL STRUCTURES)

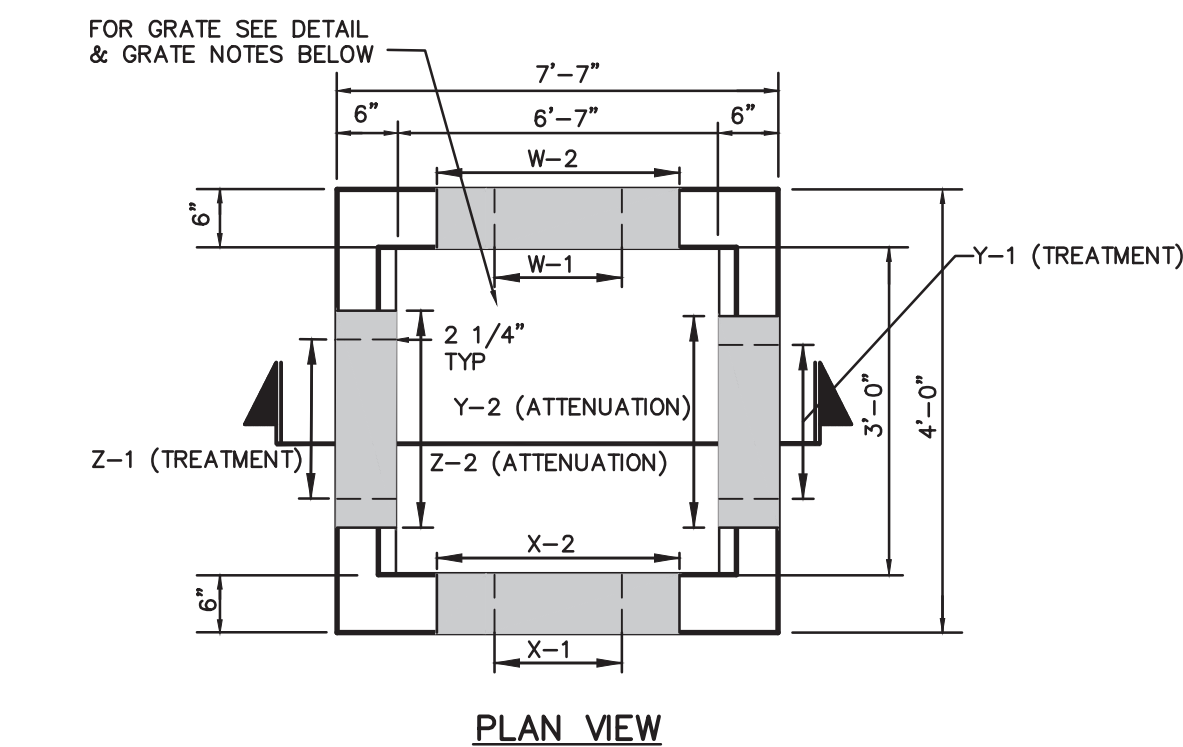

**PLAN VIEW**

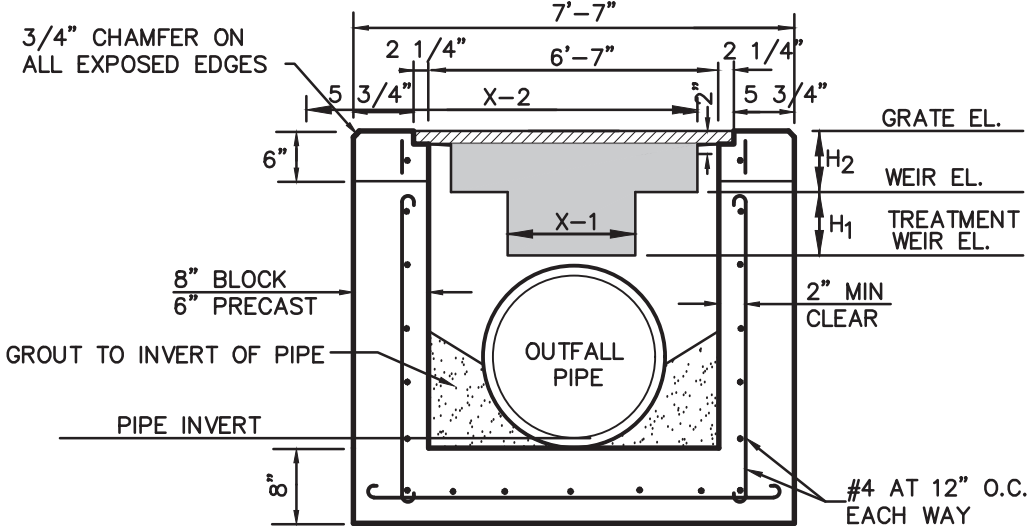

**SECTION**

- NOTES:**
- PER FDOT STANDARD PLAN 425-052
  - CONTRACTOR TO SUBMIT SHOP DRAWINGS FOR APPROVAL PRIOR TO CONSTRUCTION, SHOULD ANY VARIANCE OF THIS DETAIL BE NECESSARY.
  - BENCH MARKS WITH THE ELEVATIONS CLEARLY AND PERMANENTLY MARKED ARE TO BE PLACED ON THE TOP OF ALL OUTFALL CONTROL STRUCTURES.
  - GREASE/OIL SKIMMER TO BE ATTACHED TO WINDOW SIDE OF STRUCTURE (PER DETAIL).
  - ALL CONTROL STRUCTURES SHALL HAVE A SEPARATE TOP SLAB TO ALLOW FOR FINAL ADJUSTMENT TO DESIGN GRADE. PRECAST CONTROL STRUCTURES SHALL BE CAST SO AS TO ALLOW A MINIMUM OF 6" OF BRICK ADJUSTMENT FOR CONSTRUCTION OF THE WEIRS.
  - OUTFALL PIPE TO BE INSTALLED ON SIDE OF BOX WITHOUT WINDOW.

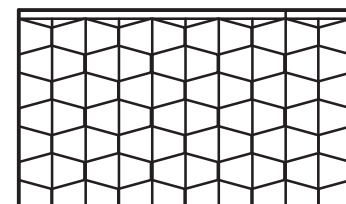

- GRATE NOTES:**
- ALL GRATES TO BE GALVANIZED STEEL.
  - TRAFFIC BEARING GRATE TO BE U.S. FOUNDRY NO. 6611.
  - NON-TRAFFIC BEARING GRATE TO BE U.S. FOUNDRY NO. 6606.
  - GRATE TO BE CHAINED TO STRUCTURE PER F.D.O.T. SPECIFICATIONS.

C.S. NUMBER	GRATE ELEVATION	"W-1" (in.)	"W-2" (in.)	"X-1" (in.)	"X-2" (in.)	"Y-1" (in.)	"Y-2" (in.)	"Z-1" (in.)	"Z-2" (in.)	TREATMENT WEIR ELEVATION	ATTENUATION WEIR ELEVATION	PIPE DIA.	PIPE INVERT
WETLAND	23.60									N/A	N/A	15.50	48"

**TYPE "H" INLET DETAIL (2 & 3-GRATE)**

N.T.S.

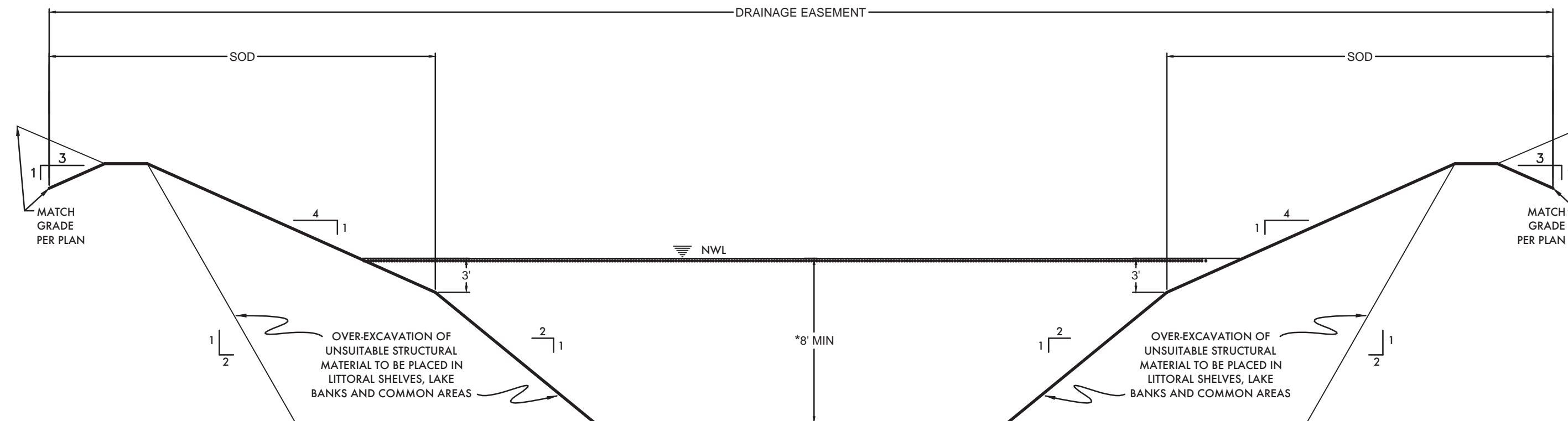

**TYPICAL SWF SECTION**

N.T.S.

- \* NOTES:**
- THE DETENTION OR RETENTION AREA SHALL NOT BE EXCAVATED TO A DEPTH THAT BREACHES AN AQUITARD SUCH THAT IT WOULD ALLOW FOR LESSER QUALITY WATER TO PASS, EITHER WAY, BETWEEN THE TWO SYSTEMS. IN THOSE GEOGRAPHICAL AREAS OF THE DISTRICT WHERE THERE IS NOT AN AQUITARD PRESENT, THE DEPTH OF THE POND SHALL NOT BE EXCAVATED TO WITHIN (2) FEET OF THE UNDERLYING LIMESTONE WHICH IS PART OF A DRINKING WATER AQUIFER.
  - SUITABLE FILL MATERIAL FROM RETENTION PONDS AS DESCRIBED IN THE GEOTECHNICAL REPORT IS LIMITED TO SOILS CLASSIFIED AS SAND, SAND WITH SILT, AND CLAYEY/SILT SAND.

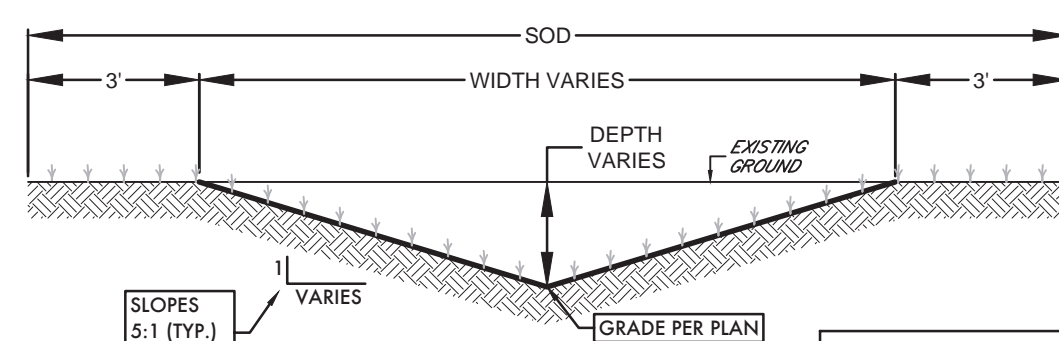

- NOTES:**
- SWALE SHALL BE INSIDE PROPERTY LINE WHERE NOT ADJACENT TO A LOT
  - SWALE SHALL BE CENTERED ON PROPERTY LINE WHERE PROPERTIES ARE ADJACENT
  - SWALE SHALL BE SODDED AS SOON AS PRACTICAL TO MINIMIZE EROSION
  - INSTALL RIP RAP WHERE SWALES MEET THE POND BANK. INSTALL RIP RAP UNDER LAID WITH GEOFABRIC FROM TOP OF BANK DOWN TO NORMAL WATER LEVEL.

**TYPICAL SWALE SECTION**

N.T.S.

**ELLIPTICAL PIPE**

DIMENSIONS & QUANTITIES

RISE R	SPAN S	X	A	B	C	E	F	G	M			
									SINGLE PIPE	DOUBLE PIPE	TRIPLE PIPE	QUAD. PIPE
12"	18"	2'-10"	1.97'	1.62'	3.59'	1.56'	4'	1.50'	4.92'	7.75'	10.58'	13.42'
14"	23"	3'-4"	2.01'	1.99'	4.02'	1.89'	5'	1.90'	5.38'	8.71'	12.04'	15.38'
19"	30"	4'-0"	2.11'	2.92'	5.03'	2.73'	6'	2.37'	6.04'	10.04'	14.04'	18.04'
24"	38"	5'-0"	2.20'	3.80'	6.05'	3.56'	7'	2.85'	6.79'	11.79'	16.79'	21.79'
29"	45"	5'-11"	2.34'	4.79'	7.13'	4.39'	8'	3.19'	7.50'	13.42'	19.33'	25.25'
34"	53"	7'-0"	2.43'	5.72'	8.15'	5.23'	9'	3.57'	8.25'	15.25'	22.25'	29.25'
38"	60"	7'-10"	2.52'	6.46'	8.98'	5.89'	9'	3.95'	8.92'	16.75'	24.58'	32.42'
43"	68"	9'-11"	2.62'	7.39'	10.01'	6.73'	10'	4.35'	8.67'	18.58'	27.50'	36.42'
48"	76"	9'-11"	2.71'	8.33'	11.04'	7.56'	11'	4.59'	10.42'	20.33'	30.25'	40.17'
53"	83"	10'-8"	2.80'	9.26'	12.06'	8.39'	12'	4.77'	11.08'	21.75'	32.42'	43.08'
58"	91"	11'-8"	2.90'	10.19'	13.09'	9.23'	13'	5.01'	11.83'	23.50'	35.17'	46.83'

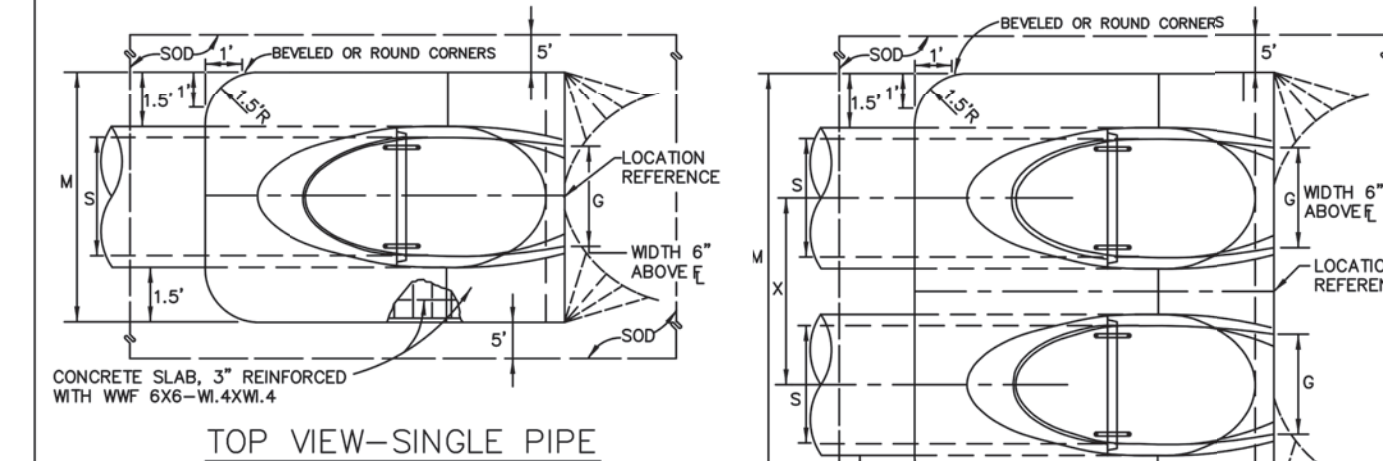

**TOP VIEW-SINGLE PIPE**

**TOP VIEW-MULTIPLE PIPE**

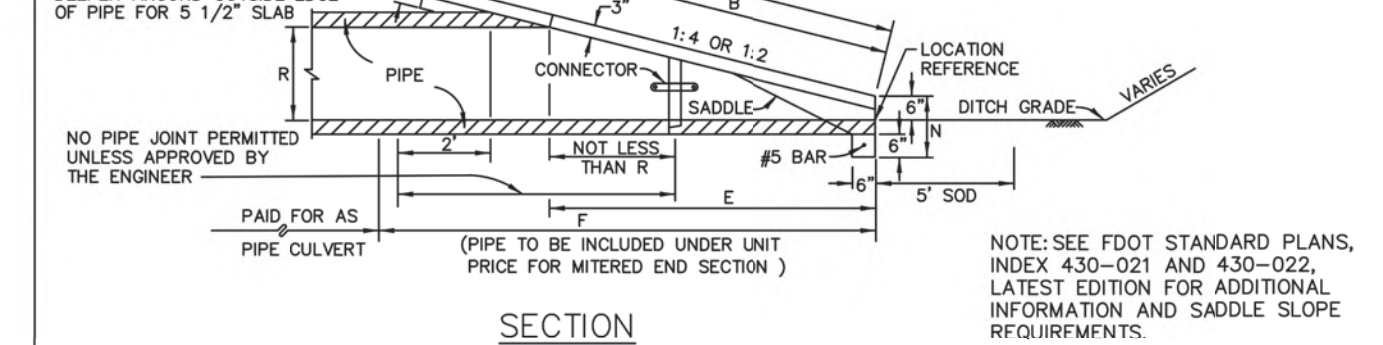

**SECTION**

MANATEE COUNTY PUBLIC WORKS DEPARTMENT	MITERED END SECTION FOR ELLIPTICAL, SINGLE AND MULTIPLE PIPES	102.2
REV. BY DATE	4/26/22	DATE OF B.O.C.C. APPROVAL

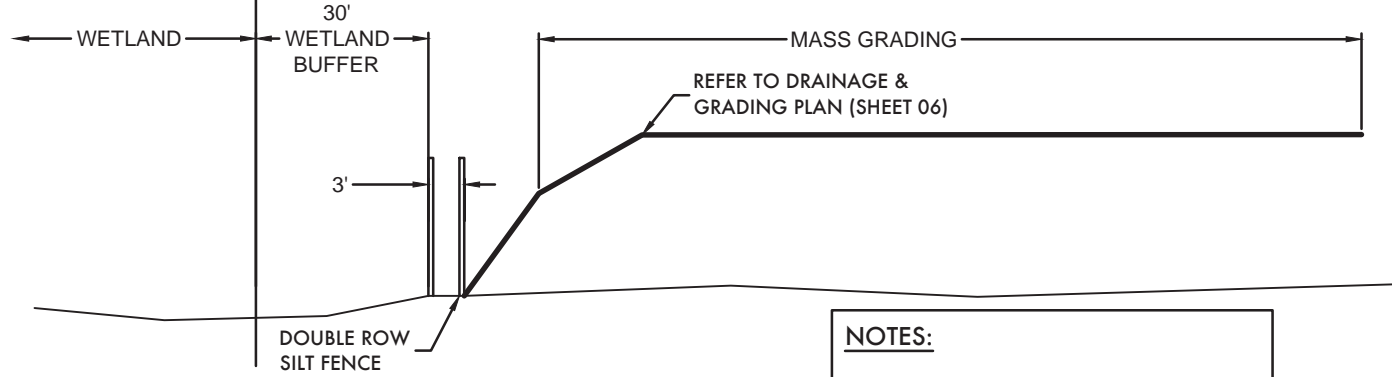

**TYPICAL MASS GRADING SECTION AT WETLAND BUFFER**

N.T.S.

- NOTES:**
- MASS GRADING SHALL NOT ENCR OACH INTO WETLAND BUFFER TO AVOID TEMPORARY BUFFER IMPACTS

ADAM J. LYON  
 PROFESSIONAL ENGINEER #8648

**ZNS ENGINEERING**  
 Land Planning  
 Engineering Surveying  
 Landscape Architecture  
 LC 0000265  
 LB 0006992  
 EB 0022476  
 1023 MANATEE AVENUE WEST 7TH FLOOR WADSWORTH, IL 34205  
 E-MAIL: ZNS@ZNSENGINEERING.COM TELEPHONE: 941.748.8090 FAX: 941.748.3316

REVISIONS

NO.	DATE	DESCRIPTION
1		
2		
3		
4		
5		
6		
7		

**GRADING AND DRAINAGE DETAILS**  
 FOR  
**GIDDENS PARCEL**  
 LOCATED IN  
 SECTION 27, TOWNSHIP 34 SOUTH, RANGE 19 EAST  
 MANATEE COUNTY, FLORIDA

DESIGNED	AL
DRAWN	EC
DATE	07/2022
JOB NO.	44229
SCALE	N/A
SHEET	07

# Tab 6



Rizzetta & Company

**UPCOMING DATES TO REMEMBER**

- **Next Meeting:** July 23, 2026
- **FY 2023-2024 Audit Completion Deadline:** Completed
- **Next Election (Seats 1, 3, & 5):** November 2026

District  
Manager's  
Report

June 25th

2026

G  
R  
E  
Y  
H  
A  
W  
K  
  
L  
A  
N  
D  
I  
N  
G  
  
C  
D  
D

<u>FINANCIAL SUMMARY</u>		<u>04/30/2026</u>
General Fund Cash Balance		\$1,407,040
Investments Operating		\$151,942
Reserve Fund Investment Balance		\$2,082,737
Debt Service Fund Investment Balance		\$981,187
Capital Projects Fund Investments		\$15,943
<b>Total Cash and Investment Balances</b>		<b>\$4,638,849</b>
<b>General Fund Expense Variance:</b>	<b>\$38,517</b>	<b>Over Budget</b>

# Tab 7

**GREYHAWK LANDING  
COMMUNITY DEVELOPMENT DISTRICT**

---

DISTRICT OFFICE · RIVERVIEW, FLORIDA (239) 936-0913  
MAILING ADDRESS · 3434 COLWELL AVENUE, SUITE 200 · TAMPA, FLORIDA 33614

**Operation and Maintenance Expenditures  
April 2026  
For Board Approval**

Attached please find the check register listing the Operation and Maintenance expenditures paid from April 1, 2026 through April 30, 2026. This does not include expenditures previously approved by the Board.

The total items being presented:                    **\$200,950.82**

Approval of Expenditures:

\_\_\_\_\_

\_\_\_\_\_ Chairperson

\_\_\_\_\_ Vice Chairperson

\_\_\_\_\_ Assistant Secretary

# Greyhawk Landing Community Development District

## Paid Operation & Maintenance Expenditures

April 1, 2026 Through April 30, 2026

<u>Vendor Name</u>	<u>Check Number</u>	<u>Invoice Number</u>	<u>Invoice Description</u>	<u>Invoice Amount</u>
Allied Universal Security Services	101091	18280905	Security Services 02/27/26 - 03/26/26	\$ 24,752.67
Allied Universal Security Services	101091	18280906	Security Services 02/27/26 - 03/26/26	\$ 1,740.20
Fitness Logic, Inc.	101086	128806	General Monthly Maintenance 03/26	\$ 135.00
Fitness Logic, Inc.	101076	129231	General Monthly Maintenance 04/26	\$ 135.00
Fitness Logic, Inc.	101107	129411	Fitness Equipment Repairs 04/26	\$ 734.47
Fitness Logic, Inc.	101108	129412	Fitness Equipment Maintenance 04/26	\$ 195.99
FL Off Duty Police	101099	GH040126	Off Duty Patrol Services 03/26	\$ 4,950.00
Florida Department of Revenue	20260417-2	5180154454887-041626	Sales Tax 04/26	\$ 123.41
Florida Power & Light Company	20260427-2	0861892289-040826	Electric Utility 03/26	\$ 40.00
Florida Power & Light Company	20260427-1	0524430428-040826	Electric Utility 03/26	\$ 57.08
Florida Power & Light Company	20260427-1	2375653280-041326	Electric Utility 03/26	\$ 38.38
Florida Power & Light Company	20260427-1	3134899503-041326	Electric Utility 03/26	\$ 40.44
Florida Power & Light Company	20260427-1	3761781131-041326	Electric Utility 03/26	\$ 641.88
Florida Power & Light Company	20260427-1	4462033285-040826	Electric Utility 03/26	\$ 65.39

# Greyhawk Landing Community Development District

## Paid Operation & Maintenance Expenditures

April 1, 2026 Through April 30, 2026

<u>Vendor Name</u>	<u>Check Number</u>	<u>Invoice Number</u>	<u>Invoice Description</u>	<u>Invoice Amount</u>
Florida Power & Light Company	20260427-1	5691779507-040826	Electric Utility 03/26	\$ 50.58
Florida Power & Light Company	20260427-1	7584230010-040826	Electric Utility 03/26	\$ 1,695.61
Florida Power & Light Company	20260427-1	81206-25366-040826	Electric Utility 03/26	\$ 195.91
Florida Power & Light Company	20260427-1	8799449502-041326	Electric Utility 03/26	\$ 39.24
Florida Power & Light Company	20260413-2	9592544168-031826	Summary Bill 02/26	\$ 5,151.08
Florida Power & Light Company	20260430-1	9592544168-041626	Summary Bill 03/26	\$ 5,289.85
Frontier Communications of FL	20260422-1	21014100550313235-032826	Internet & Phone Services 04/26	\$ 1,768.82
Joseph and Breanna Augello	101067	032626-985	Rental Deposit Refund 03/26	\$ 250.00
LaPensee Plumbing, Inc.	101069	536323	Clogged Sewer Lines [Plumbing Repairs 03/26	\$ 1,774.62
LaPensee Plumbing, Inc.	101077	537162	Clogged Sewer Lines [Plumbing Repairs 03/26	\$ 856.70
LaPensee Plumbing, Inc.	101100	537781	Guard House Restroom 04/26	\$ 366.11
Lyfe Outdoor Comfort Solutions	101087	82750	Refill Mosquito System 04/26	\$ 425.00
Main Gate Enterprises, Inc.	101095	37247	Gate Repairs 04/26	\$ 1,109.05
Main Gate Enterprises, Inc.	101109	37284	Gate Repairs 04/26	\$ 387.58

# Greyhawk Landing Community Development District

## Paid Operation & Maintenance Expenditures

April 1, 2026 Through April 30, 2026

<u>Vendor Name</u>	<u>Check Number</u>	<u>Invoice Number</u>	<u>Invoice Description</u>	<u>Invoice Amount</u>
Manatee County Sheriff's Office	101101	4933	Security Services 03/26	\$ 2,080.00
Manatee County Utilities Department	20260417-1	100020378-032626	Water Utilities 02/26	\$ 863.08
Manatee County Utilities Department	20260417-1	100020436-032626	Water Utility Charge 02/26	\$ 154.71
Manatee County Utilities Department	20260417-1	100020499-032626	Reclaim Utilities 02/26	\$ 12.78
Manatee County Utilities Department	20260417-1	100020555-032626	Reclaim Utilities 02/26	\$ 29.66
Manatee County Utilities Department	20260417-1	100020612-032626	Reclaim Utilities 02/26	\$ 22.98
Manatee County Utilities Department	20260417-1	100020663-032626	Reclaim Utilities 02/26	\$ 2.07
Manatee County Utilities Department	20260417-1	100020720-032626	Reclaim Utilities 02/26	\$ 554.37
Manatee County Utilities Department	20260417-1	100201254-032626	Water Utilities 02/26	\$ 1,220.02
Manatee County Utilities Department	20260417-1	100201320-032626	Reclaim Utilities 02/26	\$ 86.48
Manatee County Utilities Department	20260417-1	100201490-032626	Reclaim Utilities 02/26	\$ 91.62
Manatee County Utilities Department	20260417-1	100201568-032626	Reclaim Utilities 02/26	\$ 30.46
Manatee County Utilities Department	20260417-1	100201730-032626	Reclaim Utilities 02/26	\$ 14.74
Manatee County Utilities Department	20260417-1	100201813-032626	Reclaimed Water 02/26	\$ 0.12

# Greyhawk Landing Community Development District

## Paid Operation & Maintenance Expenditures

April 1, 2026 Through April 30, 2026

<u>Vendor Name</u>	<u>Check Number</u>	<u>Invoice Number</u>	<u>Invoice Description</u>	<u>Invoice Amount</u>
McClatchy Company, LLC	101078	116358	Legal Advertising 04/26	\$ 151.04
Nostalgic Lampposts & Mailboxes Plus, Inc.	101113	3936	Lighting Repair 02/26	\$ 399.90
Nostalgic Lampposts & Mailboxes Plus, Inc.	101110	3949	Lighting Repair 02/26	\$ 512.60
Nostalgic Lampposts & Mailboxes Plus, Inc.	101110	4018	Lighting/Lamppost Repair 03/26	\$ 8,701.91
Nostalgic Lampposts & Mailboxes Plus, Inc.	101110	4026	Maintenance Street Lights 03/26	\$ 1,400.00
Nostalgic Lampposts & Mailboxes Plus, Inc.	101110	4034	Lighting Repair 03/26	\$ 512.60
Nostalgic Lampposts & Mailboxes Plus, Inc.	101110	4152	Maintenance Street Lights 04/26	\$ 1,400.00
Nostalgic Lampposts & Mailboxes Plus, Inc.	101110	4159	Lighting Repair 04/26	\$ 387.60
Nostalgic Lampposts & Mailboxes Plus, Inc.	101110	4189	Lighting Repair 04/26	\$ 445.75
Owens Electric, Inc.	101079	40223180	Replace Lights 03/26	\$ 1,187.50
Owens Electric, Inc.	101102	40226357	Replace Lights 04/26	\$ 1,187.50
Persson, Cohen & Mooney, P.A.	101096	6881	Legal Services 03/26	\$ 2,176.76
Pools by Lowell, Inc.	101080	214691797	Pool Repairs/Maintenance 03/26	\$ 298.89
Pools by Lowell, Inc.	101080	214732449	Chlorine Barrel Replacement 03/26	\$ 94.50

# Greyhawk Landing Community Development District

## Paid Operation & Maintenance Expenditures

April 1, 2026 Through April 30, 2026

<u>Vendor Name</u>	<u>Check Number</u>	<u>Invoice Number</u>	<u>Invoice Description</u>	<u>Invoice Amount</u>
Pools by Lowell, Inc.	101088	214976014	Spa Repairs 04/26	\$ 597.52
Pools by Lowell, Inc.	101080	214983536	Commercial Pool Service 04/26	\$ 2,250.00
Pools by Lowell, Inc.	101070	214983547	Commercial Pool Service 04/26	\$ 1,600.00
Pools by Lowell, Inc.	101088	215027239	Pool Repairs 04/26	\$ 311.64
Pools by Lowell, Inc.	101088	215075875	Spa Repairs 04/26	\$ 126.56
Pools by Lowell, Inc.	101088	215076046	Pool Repairs - Stenner Feeder Pump 04/26	\$ 168.68
Pools by Lowell, Inc.	101088	215077803	Pool Repairs 04/26	\$ 302.57
Pools by Lowell, Inc.	101088	215080368	Pool/Spa Repairs 04/26	\$ 345.50
Pools by Lowell, Inc.	101103	215417638	Spa Inline Thermometer 04/26	\$ 74.59
Pools by Lowell, Inc.	101114	251961575	Pool Repair 04/26	\$ 125.00
Redwire	101084	638493	Fire System/Monthly Monitoring Service 04/26	\$ 201.40
Redwire	101112	642746	Fire System/Monthly Monitoring Service 05/26	\$ 201.40
Rizzetta & Company, Inc.	101068	INV0000108132	Accounting Services 04/26	\$ 5,831.83
Rizzetta & Company, Inc.	101066	INV0000108164	Personnel Reimbursement 03/26	\$ 7,435.09

# Greyhawk Landing Community Development District

## Paid Operation & Maintenance Expenditures

April 1, 2026 Through April 30, 2026

<u>Vendor Name</u>	<u>Check Number</u>	<u>Invoice Number</u>	<u>Invoice Description</u>	<u>Invoice Amount</u>
Rizzetta & Company, Inc.	101089	INV0000108198	Cell Phone 03/26	\$ 50.00
Rizzetta & Company, Inc.	101090	INV0000108226	Personnel Reimbursement 04/26	\$ 8,618.37
Rizzetta & Company, Inc.	101106	INV0000109094	Personnel Reimbursement 04/26	\$ 7,431.54
Samuel and Susan Swetland	101092	041026-985	Rental Deposit Refund 04/26	\$ 250.00
Sarasota Gate and Access	101071	246542	Access Control Maintenance & Repair 03/26	\$ 4,868.00
Say No to Bugs, Inc.	101081	130009	Pest Control 03/25	\$ 325.00
Schappacher Engineering, LLC	101082	3020	Engineering Services 03/26	\$ 2,763.75
Sitex Aquatics, LLC	101097	10948-b	Aquatic Maintenance 04/26	\$ 9,954.00
Southeast Spreading Company, LLC	101111	47993	Mulch Application 04/26	\$ 16,648.77
Spectrum	20260429-5	34318041026	Internet Grayhawk Blvd 04/26	\$ 239.43
Spectrum	20260420-1	8337120131816996-040126	Internet: 700 Greyhawk Blvd-Gym 04/26	\$ 38.52
Sun State Landscape Management, Inc.	101072	71792	Irrigation Repairs 03/26	\$ 892.84
Sun State Landscape Management, Inc.	101085	72214	Irrigation Piping 03/26	\$ 5,000.00
Sun State Landscape Management, Inc.	101093	72300	Irrigation Repairs 03/26	\$ 4,015.00

# Greyhawk Landing Community Development District

## Paid Operation & Maintenance Expenditures

April 1, 2026 Through April 30, 2026

<u>Vendor Name</u>	<u>Check Number</u>	<u>Invoice Number</u>	<u>Invoice Description</u>	<u>Invoice Amount</u>
Sun State Landscape Management, Inc.	101093	72334	Tree Installation 03/26	\$ 1,250.00
Sun State Landscape Management, Inc.	101104	72349	March Irrigation Repairs	\$ 1,104.40
Sun State Landscape Management, Inc.	101098	72366	Irrigation Inspections - Monthly 04/26	\$ 28,564.59
Sun State Landscape Management, Inc.	101093	72468	Fire Ant Treatment 04/26	\$ 468.75
Sun State Landscape Management, Inc.	101105	72469	Fertilization 04/26	\$ 4,725.00
Sun State Landscape Management, Inc.	101105	72533	Directional Boring 04/26	\$ 2,600.00
Sun State Landscape Management, Inc.	101115	72739	Landscape Replacement 04/26	\$ 300.00
Sun State Landscape Management, Inc.	101115	72740	Landscape Replacement 04/26	\$ 500.00
Sun State Landscape Management, Inc.	101115	72741	Landscape Replacement 04/26	\$ 75.00
Sun State Landscape Management, Inc.	101115	72742	Landscape Replacement 04/26	\$ 255.00
Sun State Landscape Management, Inc.	101115	72743	Landscape Maintenance 04/26	\$ 350.00
TECO Peoples Gas	20260401-1	211012697549-031026	Natural Gas Charges 02/26	\$ 23.00
TFR Cleaning Services, Inc.	101083	91131	Janitorial Services 04/26	\$ 1,000.00
Tim Schellenger	101094	041026-985	Rental Deposit Refund 04/26	\$ 250.00

# Greyhawk Landing Community Development District

## Paid Operation & Maintenance Expenditures

April 1, 2026 Through April 30, 2026

<u>Vendor Name</u>	<u>Check Number</u>	<u>Invoice Number</u>	<u>Invoice Description</u>	<u>Invoice Amount</u>
Valley National Bank	20260428-1	CC033126-985	Credit Card Expenses 03/26	\$ 1,698.03
Verizon Wireless	20260413-1	6139168334	Phone Service -Account 820583362 03/26	\$ 90.35
<b>Total</b>				<b><u>\$ 200,950.82</u></b>

# Tab 8

MINUTES OF MEETING

Each person who decides to appeal any decision made by the Board with respect to any matter considered at the meeting is advised that the person may need to ensure that a verbatim record of the proceedings is made, including the testimony and evidence upon which such appeal is to be based.

GREYHAWK LANDING COMMUNITY DEVELOPMENT DISTRICT

The regular meeting of the Board of Supervisors of the Greyhawk Landing Community Development District was held on Thursday, April 23, 2026, at 6:00 p.m. at the Greyhawk Landing Clubhouse, located at 12350 Mulberry Avenue, Bradenton, FL 34212.

Present and constituting a quorum:

- Jim Hengel Board Supervisor, Chairman
Mark Bush Board Supervisor, Vice Chairman
Cheri Ady Board Supervisor, Assistant Secretary
Chad Chester Board Supervisor, Assistant Secretary

Also present were:

- Matt O’Nolan District Manager, Rizzetta & Company, Inc.
Andrew Davis Field Manager, Rizzetta & Company, Inc.
Rick Schappacher District Engineer, Schappacher Engineering
Syd Roberts Sun State Landscape Management, Inc.
Bert Smith Representative, Sitex
Dan Lewis District Counsel – Persson, Cohen, Mooney, Fernandez & Jackson, P.A. (via phone)

Audience Present

FIRST ORDER OF BUSINESS

Call to Order

Mr. O’Nolan called the meeting to order and conducted roll call.

The Board recited the Pledge of Allegiance.

SECOND ORDER OF BUSINESS

Audience Comments

The Board heard comments on street parking, gate arms and FHP increased patrols.

THIRD ORDER OF BUSINESS

Staff Reports & Updates

A. Aquatic Maintenance

Mr. Smith provided the Board with his report and spoke about Lakes 34 and 35.

48 Mr. Smith will investigate concerns at preserve 36.

49

50 **B. Landscape Maintenance**

51 Mr. Roberts reviewed his report with the Board.

52

53 **C. Field Manager**

54 Mr. Davis provided the Board with his report.

55

56 Mr. O’Nolan will get with Mr. Cohen on pressure washing and send demand letter.

57

58 Mr. Davis will follow up with Mr. Roberts concerning wall plants on 117.

59

60 **D. District Counsel**

61 Mr. Cohen provided the Board with his report.

62

63 The Board requested Counsel send demand letter to Will Butler to attend next  
64 board meeting to discuss his pressure washing contract and progress.

65

66 **E. District Engineer**

67 Mr. Schappacher provided the Board with his report.

68

69 The Board approved the District Engineer looking into CDD property regarding the  
70 pavers on Chantilly.

71

72 **F. District Manager**

73 Mr. O’Nolan advised the next regular meeting of the Board of Supervisors is  
74 scheduled for Thursday, May 21, 2026, at 6:00 p.m.

75

76 Supervisor Chester and Ady cannot attend the May 21 meeting. Discussion ensued  
77 on additional meeting date being scheduled. Ms. Bregg to send out email for  
78 availability for May 14 or 27th.

79

80 **FOURTH ORDER OF BUSINESS**

**Ratification of Audit Engagement  
Letter**

81

82

83 On a Motion by Ms. Ady, seconded Mr. Hengel, with all in favor, the Board ratified the  
84 Audit engagement letter, for the Greyhawk Landing Community Development District.

85

86 **FIFTH ORDER OF BUSINESS**

**Discussion of Vacant Board Seat**

87

88 On a Motion by Mr. Hengel, seconded Mr. Bush, with all in favor, the Board accepted Ms.  
89 Ady’s resignation and vacated seat 1, for the Greyhawk Landing Community Development  
90 District.

91

92

93 On a Motion by Mr. Hengel, seconded Mr. Bush, with all in favor, the Board nominated  
94 and approved appointing Cheri Ady to Seat 4 and was sworn in, for the Greyhawk Landing  
95 Community Development District.

96  
97 **SIXTH ORDER OF BUSINESS**

**Discussion of pavers on Chantilly**

98  
99 The Board approved District Engineer looking into CDD property regarding the  
100 pavers on Chantilly.

101  
102 **SEVENTH ORDER OF BUSINESS**

**Review of the Financial Statement for  
March 2026**

103  
104  
105 The Board reviewed the financial statement for March 2026.

106  
107 **EIGHTH ORDER OF BUSINESS**

**Review of the Operations and  
Maintenance Expenditures for the  
Month of March 2026**

108  
109  
110  
111 The Board reviewed the Operations and Maintenance Expenditures for the month  
112 of March 2026

113  
114 **NINTH ORDER OF BUSINESS**

**Consideration of Minutes of Board of  
Supervisors Meeting held on February  
26, 2026**

115  
116  
117  
118 On a Motion by Mr. Hengel, seconded Mr. Bush, with all in favor, the Board approved the  
119 March 2026 Operations and Maintenance Expenditures (\$196,187.78) and approved the  
120 meeting minutes of Board of Supervisors held on February 26, 2026, for the Greyhawk  
121 Landing Community Development District.

122  
123 **TENTH ORDER OF BUSINESS**

**Supervisor Requests**

124  
125 No supervisor requests were made.

126  
127 **ELEVENTH ORDER OF BUSINESS**

**Adjournment**

128  
129 Mr. O’Nolan advised there was no further business to come before the Board and  
130 asked for a motion to adjourn.

131  
132 On a Motion by Mr. Chester, seconded Ms. Ady, with all in favor, the Board Adjourned the  
133 Meeting at 7:39 p.m., for the Greyhawk Landing Community Development District.

134  
135  
136  
137

138  
139  
140  
141  
142  
143  
144  
145  
146  
147  
148  
149  
150  
151  
152  
153

---

Secretary / Assistant Secretary

---

Chairman / Vice Chairman

DRAFT

**MINUTES OF MEETING**

*Each person who decides to appeal any decision made by the Board with respect to any matter considered at the meeting is advised that the person may need to ensure that a verbatim record of the proceedings is made, including the testimony and evidence upon which such appeal is to be based.*

**GREYHAWK LANDING COMMUNITY DEVELOPMENT DISTRICT**

The workshop meeting of the Board of Supervisors of the Greyhawk Landing Community Development District was held on **Wednesday, May 27, 2026, at 5:00 p.m.** at the Greyhawk Landing Clubhouse, located at 12350 Mulberry Avenue, Bradenton, FL 34212.

Present and constituting a quorum:

Jim Hengel	<b>Board Supervisor, Chairman</b>
Mark Bush	<b>Board Supervisor, Vice Chairman</b>
Chad Chester	<b>Board Supervisor, Assistant Secretary</b>

Also present were:

Matt O’Nolan	<b>District Manager, Rizzetta &amp; Company, Inc.</b>
Nancy Bregg	<b>District Coordinator, Rizzetta &amp; Company, Inc</b>

Audience	Present
----------	---------

**FIRST ORDER OF BUSINESS**

**Call to Order**

Mr. O’Nolan called the meeting to order and conducted roll call.

The Board recited the Pledge of Allegiance.

**SECOND ORDER OF BUSINESS**

**Audience Comments**

The Board heard comment on pond algae concerns being included in budget.

**THIRD ORDER OF BUSINESS**

**Discussion of Proposed Fiscal Year 2026-2027 Budget**

The Board held an in-depth discussion on the Proposed Fiscal Year 2026-2027 budget.

48  
49  
50  
51  
52  
53  
54  
55  
56  
57  
58  
59

---

Secretary / Assistant Secretary

---

Chairman / Vice Chairman

DRAFT

MINUTES OF MEETING

Each person who decides to appeal any decision made by the Board with respect to any matter considered at the meeting is advised that the person may need to ensure that a verbatim record of the proceedings is made, including the testimony and evidence upon which such appeal is to be based.

GREYHAWK LANDING COMMUNITY DEVELOPMENT DISTRICT

The regular meeting of the Board of Supervisors of the Greyhawk Landing Community Development District was held on **Wednesday, May 27, 2026, at 6:00 p.m.** at the Greyhawk Landing Clubhouse, located at 12350 Mulberry Avenue, Bradenton, FL 34212.

Present and constituting a quorum:

Jim Hengel	<b>Board Supervisor, Chairman</b>
Mark Bush	<b>Board Supervisor, Vice Chairman</b>
Chad Chester	<b>Board Supervisor, Assistant Secretary</b>

Also present were:

Matt O’Nolan	<b>District Manager, Rizzetta &amp; Company, Inc.</b>
Nancy Bregg	<b>District Coordinator, Rizzetta &amp; Company, Inc.</b>
Andrew Davis	<b>Field Manager, Rizzetta &amp; Company, Inc.</b>
Rick Schappacher	<b>District Engineer, Schappacher Engineering</b>
Syd Roberts	<b>Sun State Landscape Management, Inc.</b>
Haley Pryor	<b>Landscape Inspection Specialist, Rizzetta &amp; Company, Inc.</b>
Bert Smith	<b>Representative, Sitex</b>
Carlos Trujillo	<b>Representative, SSLM</b>
Andrew Cohen	<b>District Counsel – Persson, Cohen, Mooney, Fernandez &amp; Jackson, P.A.</b>

Audience Present

**FIRST ORDER OF BUSINESS**

**Call to Order**

Mr. O’Nolan called the meeting to order and conducted roll call.

**SECOND ORDER OF BUSINESS**

**Audience Comments**

The Board heard comments on street parking, ponds and gates.

**THIRD ORDER OF BUSINESS**

**Staff Reports & Updates**

**A. Presentation of Community Asset Report**

Ms. Pryor reviewed her report to the Board and spoke about turf, water restrictions, removing stakes and tree girdling.

Mr. Roberts reviewed his report with the Board and spoke about vegetation growth, final fertilization, irrigation repairs, turf conditions, and tree care.

**B. Aquatic Maintenance**

Mr. Smith reviewed his report and provided an update to the Board and spoke about aquatic growth, Hydrilla treatment, Dissolved Oxygen Management, aeration systems, pond 45 and preserve management.

**C. District Counsel**

Mr. Cohen provided his report to the Board and spoke about the Gatehouse damage and advised a demand letter was sent on May 5, 2026, to CBG Construction LLC. The company has been unresponsive. The Board directed Mr. Cohen to file a report with the Manatee County Sheriff's Department for leaving the scene of an accident involving property damage.

**D. District Engineer**

Mr. Schappacher reviewed his report with the Board and spoke about lake certification, resident violations, pond maintenance, storm system access and the development impact on Highway 117 to community ponds.

The Board requested District Counsel and Engineer coordinate on notifying/resolving residents' causing pond bank erosion and landscaping damage.

**E. Field Manager**

Mr. Davis reviewed his report with the Board and spoke about roadmap items, streambed paint refresh, role responsibilities, enforcing amenity rules, corrective measure timelines, hours of operation, the splash pad motor arrival, pond aerators, irrigation issues and emergency clicker for the County.

The Board requested Field Manager file a police report for the damage to the gate house.

The Board requested Field Manager tour the community with the pressure washing vendor to identify any missed areas.

**F. District Manager**

Mr. O'Nolan advised the next regular meeting of the Board of Supervisors is scheduled for Thursday, June 25, 2026, at 6:00 p.m.

The registered voter count was read into the record 2,703 registered voters.



139 **ELEVENTH ORDER OF BUSINESS** **Review of Financial Statement for**  
140 **April 2026**

141  
142 The Board reviewed the Financial Statement for April 2026.

143  
144  
145 **TWELFTH ORDER OF BUSINESS** **Consideration of the Operations and**  
146 **Maintenance Expenditures for the**  
147 **Month of March 2026**

148  
149 The Board reviewed the Operations and Maintenance Expenditures for the month  
150 of March 2026

151  
152 **THIRTEENTH ORDER OF BUSINESS** **Consideration of the Meeting Minutes**  
153 **held on March 26, 2026**

154  
155 On a Motion by Ms. Mathews, seconded Mr. Bush, with all in favor, the Board approved  
156 the March 2026 Operations and Maintenance Expenditures (\$196,187.78) and the  
157 meeting minutes of Board of Supervisors meeting held on March 26, 2026, for the  
158 Greyhawk Landing Community Development District.

159  
160 **FOURTEENTH ORDER OF BUSINESS** **Consideration of the 1<sup>st</sup> Quarter**  
161 **Website Audit**

162  
163 On a Motion by Mr. Hengel, seconded Mr. Chester, with all in favor, the Board approved  
164 the 1<sup>st</sup> quarter website audit as presented, for the Greyhawk Landing Community  
165 Development District.

166  
167  
168 **FIFTEENTH ORDER OF BUSINESS** **Supervisor Requests**

169  
170 No requests were made at the meeting.

171  
172 **SIXTEETH ORDER OF BUSINESS** **Adjournment**

173  
174 Mr. O’Nolan advised there was no further business to come before the Board and  
175 asked for a motion to adjourn.

176  
177 On a Motion by Mr. Hengel, seconded Mr. Chester, with all in favor, the Board Adjourned  
178 the Meeting at 7:52 p.m., for the Greyhawk Landing Community Development District.

179  
180  
181  
182  
183

184  
185  
186  
187  
188  
189  
190  
191  
192  
193  
194  
195  
196  
197  
198  
199  
200  
201  
202

---

Secretary / Assistant Secretary

---

Chairman / Vice Chairman

DRAFT